



Our *passion* is enclosures.



polyDOOR

Enclosures with integrated covers made of glass fibre reinforced polyester

Technical data

polyDOOR



With integrated hinges



Version with window FE

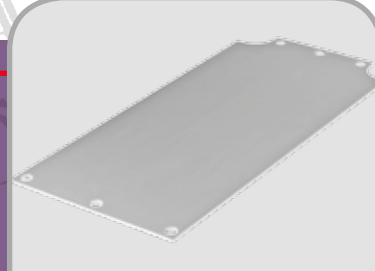

Mounting plate

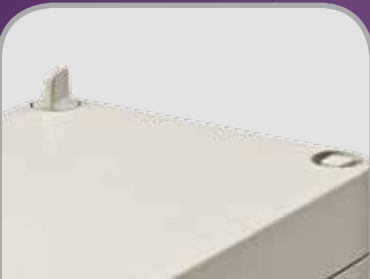

Large selection of...



...locking screws



Cross rail



Mounting rail and terminals

Enclosure: Polyester glass fibre reinforced, halogen-free
1° mould slope for casting ejection, internal measures diminishing
circulatory towards enclosure bottom by 1°.

Components: Mounting socket with M6
threaded bushing in the lower section.

Fastening: Space-saving single-channel technology

Flammability: UL 94 V-0, self-extinguishing

Type of protection: IP66 / EN 60529

Gasket: Chloroprene (CR) gasket (-30°C to +90°C)

Lid screws: Polyamide (PA), captive

Surface: RAL 7032, silky grey, surface resistance > 10⁹ Ω

Optionally available:

External mounting feet: Stainless steel 1.4301 (V2A)

Mounting plates: Sheet steel, galvanised

Gasket: Silicon gasket (-50°C to +140°C)

Surface: RAL 9005, deep black, surface resistance < 10⁹ Ω

Further options, see delivery overview.

Delivery overview polyDOOR

Type	Mat. no.	L	W	H	D	E	g	S	V	W	X	H	M	A	T*	Q
PD 120	130.120.000	140	120	100	118	98	850	☐	☐	●	●	●	●	●	●	●
PD 122	130.122.000	200	120	100	178	98	1.060	☐	☐	●	●	●	●	●	●	●
PD 124	130.124.000	260	120	100	238	98	1.250	☐	☐	●	●	●	●	●	●	●
PD 160	130.160.000	180	160	100	158	138	1.180	☐	☐	●	●	●	●	●	●	●
PD 162	130.162.000	260	160	100	238	138	1.500	☐	☐	●	●	●	●	●	●	●
PD 164	130.164.000	340	160	100	318	138	1.790	☐	☐	●	●	●	●	●	●	●
PD 200	130.200.000	220	200	120	198	178	1.800	☐	☐	●	●	●	●	●	●	●
PD 202	130.202.000	320	200	120	298	178	2.280	☐	☐	●	●	●	●	●	●	●
PD 120 FE	131.120.000	140	120	100	118	98	850	☐	☐	●	●	●	●	●	●	●
PD 122 FE	131.122.000	200	120	100	178	98	1.060	☐	☐	●	●	●	●	●	●	●
PD 124 FE	131.124.000	260	120	100	238	98	1.250	☐	☐	●	●	●	●	●	●	●
PD 160 FE	131.160.000	180	160	100	158	138	1.180	☐	☐	●	●	●	●	●	●	●
PD 162 FE	131.162.000	260	160	100	238	138	1.500	☐	☐	●	●	●	●	●	●	●
PD 164 FE	131.164.000	340	160	100	318	138	1.790	☐	☐	●	●	●	●	●	●	●
PD 200 FE	131.200.000	220	200	120	198	178	1.800	☐	☐	●	●	●	●	●	●	●
PD 202 FE	131.202.000	320	200	120	298	178	2.280	☐	☐	●	●	●	●	●	●	●

* T can only be mounted with Q

☐ Standard ● Available ○ Not available

Approvals:

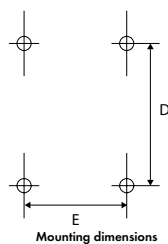
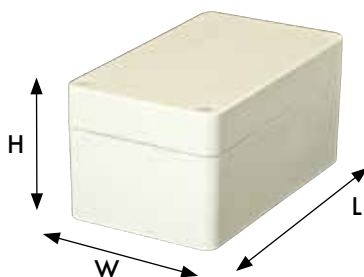

ROLEC Attachment and mounting dimensions

polyDOOR

PD 120

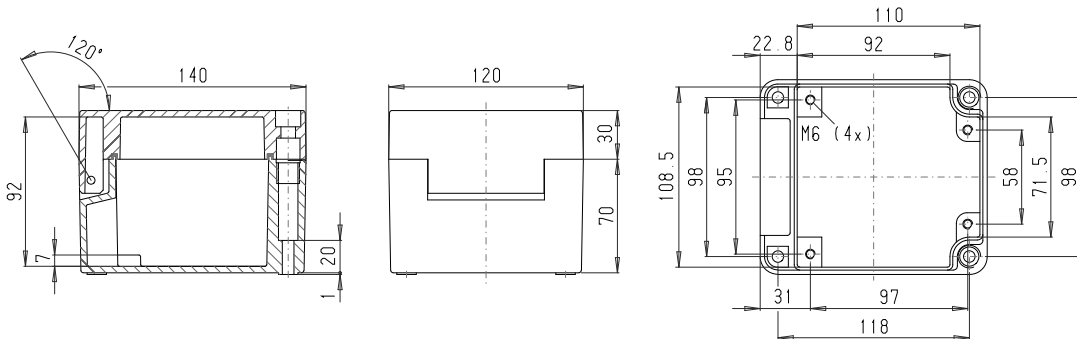

Maximum number of cable glands per enclosure side			
C	A		D
	B	D	
M 16	PG 7	12	9
	PG 9	8	6
M 20	PG 11	8	5
	PG 13,5	5	4
M 25	PG 16	4	4
	PG 21	3	
M 32	PG 29	1	
M 40	PG 36		
M 50	PG 42		
M 63	PG 48		

PD 122

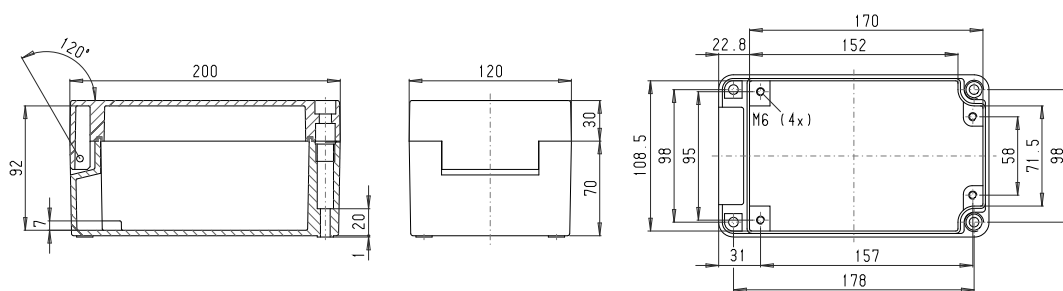

Maximum number of cable glands per enclosure side			
C	A		D
	B	D	
M 16	PG 7	12	9
	PG 9	11	6
M 20	PG 11	11	5
	PG 13,5	8	4
M 25	PG 16	5	4
	PG 21	3	
M 32	PG 29	3	
M 40	PG 36		
M 50	PG 42		
M 63	PG 48		

PD 124

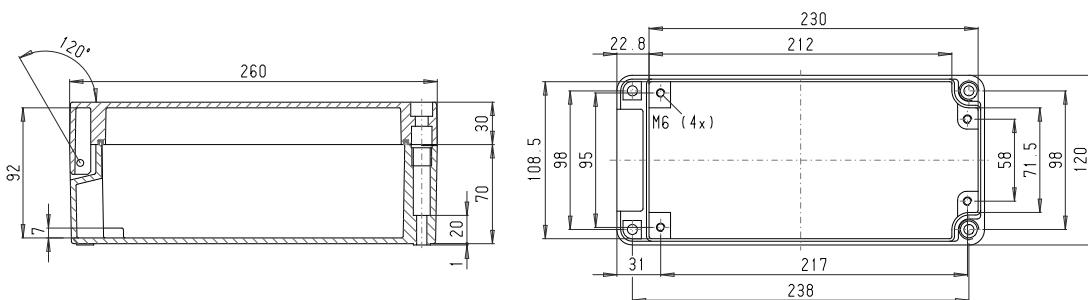

Maximum number of cable glands per enclosure side			
C	A		D
	B	D	
M 16	PG 7	20	9
	PG 9	17	6
M 20	PG 11	14	5
	PG 13,5	11	4
M 25	PG 16	7	4
	PG 21	4	
M 32	PG 29	3	
M 40	PG 36		
M 50	PG 42		
M 63	PG 48		

PD 160

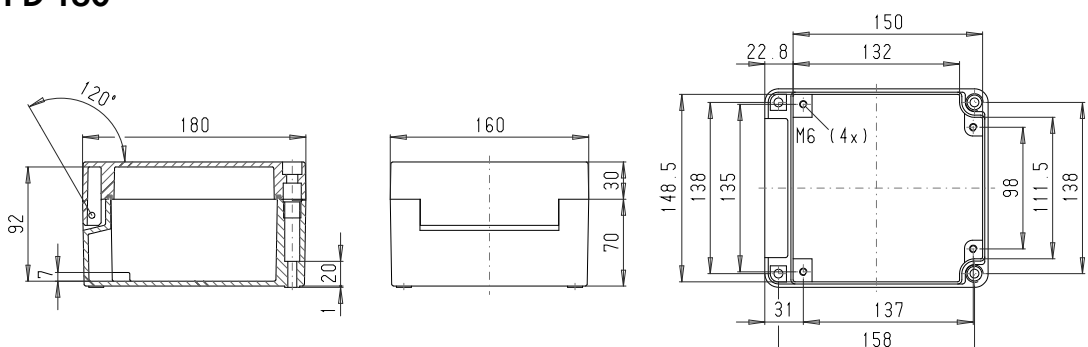

Maximum number of cable glands per enclosure side			
C	A		D
	B	D	
M 16	PG 7	15	4
	PG 9	14	3
M 20	PG 11	9	2
	PG 13,5	8	2
M 25	PG 16	6	2
	PG 21	2	
M 32	PG 29	2	
M 40	PG 36	1	
M 50	PG 42		
M 63	PG 48		

PD 162

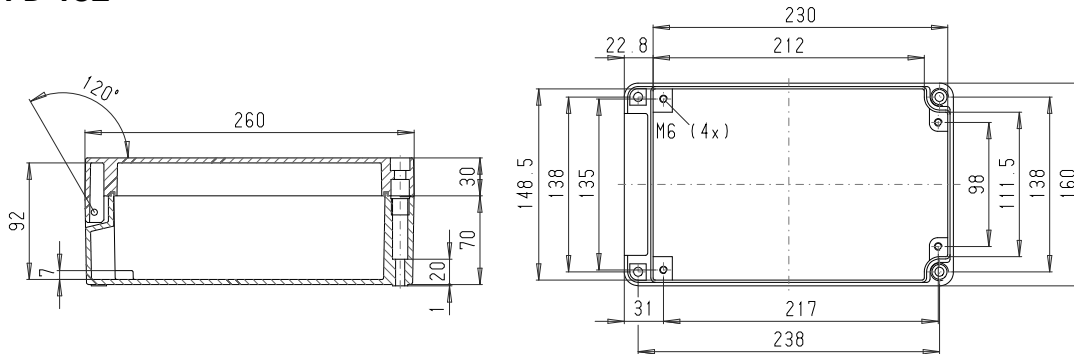

Maximum number of cable glands per enclosure side

C	A		A/B	D
	B	D		
		PG 7	24	4
M 16		PG 9	21	3
		PG 11	12	2
M 20		PG 13,5	10	2
		PG 16	4	
M 25		PG 21	3	
M 32		PG 29	3	
M 40		PG 36	2	
M 50		PG 42		
M 63		PG 48		

PD 164

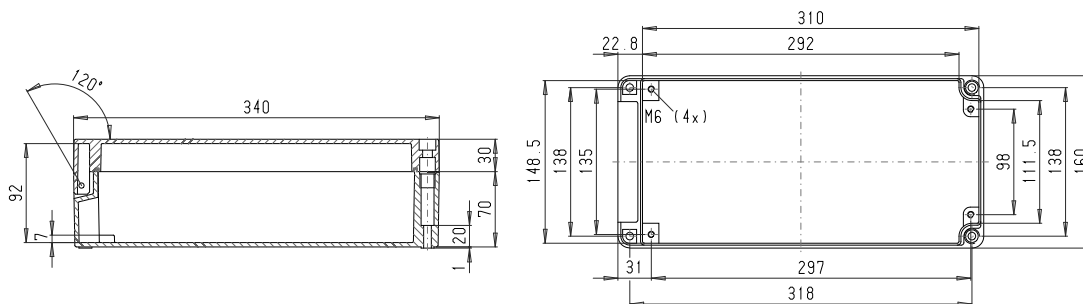

Maximum number of cable glands per enclosure side

C	A		A/B	D
	B	D		
		PG 7	36	4
M 16		PG 9	24	3
		PG 11	21	2
M 20		PG 13,5	13	2
		PG 16	6	
M 25		PG 21	4	
M 32		PG 29	3	
M 40		PG 36	3	
M 50		PG 42		
M 63		PG 48		

PD 200

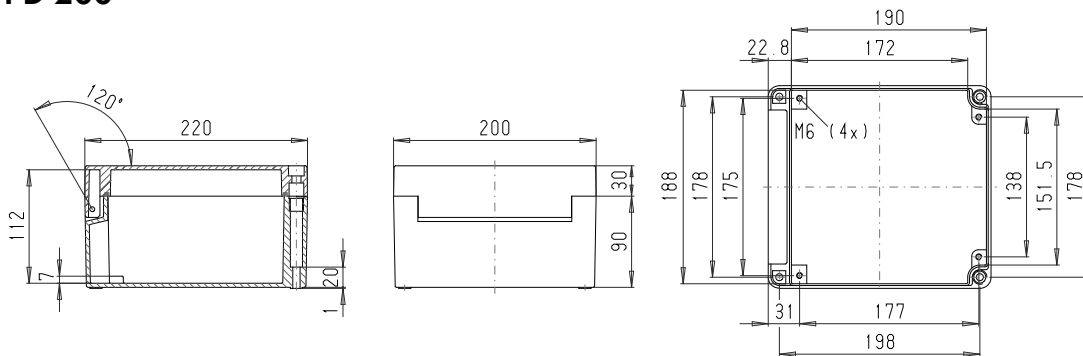

Maximum number of cable glands per enclosure side

C	A		A/B	D
	B	D		
		PG 7	30	30
M 16		PG 9	21	21
		PG 11	18	12
M 20		PG 13,5	14	11
		PG 16	9	9
M 25		PG 21	8	5
M 32		PG 29	4	3
M 40		PG 36	2	2
M 50		PG 42		
M 63		PG 48		

PD 202

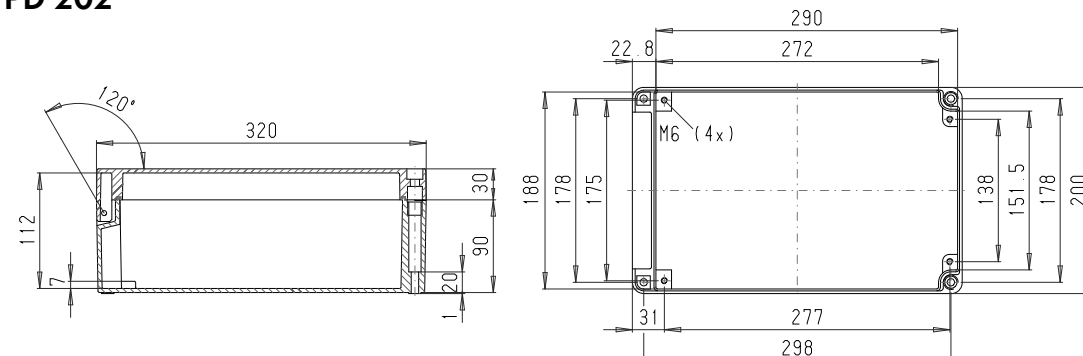

Maximum number of cable glands per enclosure side

C	A		A/B	D
	B	D		
		PG 7	50	30
M 16		PG 9	33	21
		PG 11	27	12
M 20		PG 13,5	21	11
		PG 16	15	9
M 25		PG 21	13	5
M 32		PG 29	6	3
M 40		PG 36	4	2
M 50		PG 42		
M 63		PG 48		

